

CUBE

Il sistema CUBE disegnato da Cesana Associati, dinamica e flessibile combinazione di basi e contenitori a sviluppo orizzontale, rappresenta una sintesi elegante di uno stile di vita contemporaneo, attento al design e ai valori tecnologici.
The CUBE system, designed by Cesana Associati, is a dynamic and flexible combination of horizontal expansion bases and containers. It is the condensed point of modern lifestyle, focused on design and technical values.
CUBE, créé par Cesana Associati, est une combinaison dynamique et flexible de bases et récipients à extension horizontale.
CUBE représente une synthèse élégante d'un système de vie contemporain, attentif au design et aux valeurs technologiques.

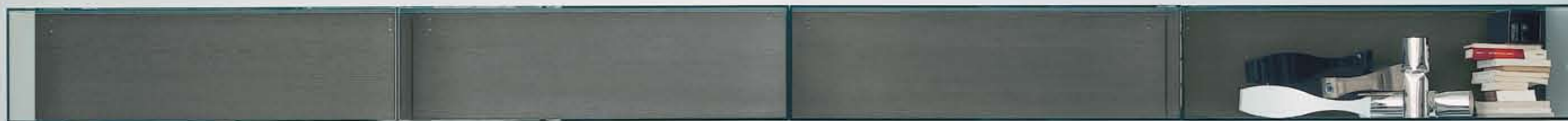

Pensili verticali ed orizzontali in rovere bianco poro aperto. Panche in laccato nero lucido.
Vertical and horizontal hanging units finished in white lacquered oak. Low units finished in high glossy black.
Meubles à mur verticaux et horizontaux en chêne teinté blanc. Meuble bas en noir brillante.

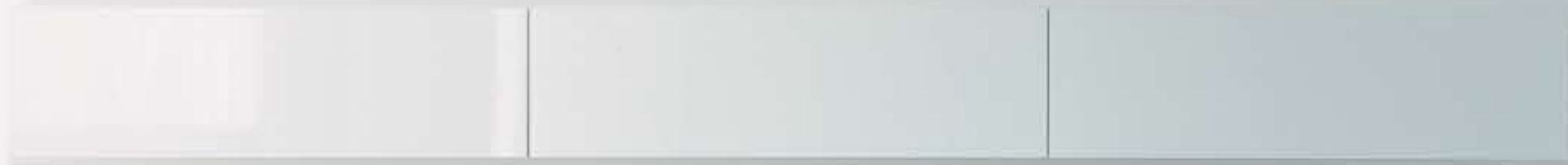

04



dettagli raffi
nati, materiali
preziosi
e
proporzioni
calibrate

Particolari del volume pensile completamente trasparente con lo schienale in essenza rovere tinto grigio.
Details of the totally transparent hanging element with grey oak veneered back panel.
Détails du volume suspendu complètement transparent avec la partie postérieure plaquée en chêne gris.



E

B

D

C

Composizione di grande dinamicità con i contenitori sovrapposti : il volume in rovere tinto wengé poggia laccata bianco lucido con cassettoni. I pensili in cristallo trasparente hanno lo schienale laccato bianco lucente.
Great dynamic composition with the "one on an other" containers: the wengé oak veneered element stands on lacquered drawers base. The transparent glass hanging elements are equipped with a glossy white lacquered backrest.
Composition très dynamique avec les cubes de rangement superposés : le volume en chêne teint wengé repose sur la base laquée blanc brillant avec grands tiroirs. Les éléments suspendus en cristal transparent ont laquée blanc brillant.





Le immagini mostrano l'apertura dei cassettoni della base e la maniglia incassata sul top.
The pictures show the opening of the drawers of the base and the top integrated handle.
Les images montrent l'ouvertures des grands tiroirs de la base et la poignée encastrée sur le top.



E

B

U

C

Particolari del volume pensile completamente trasparente con lo schienale laccato bianco lucido.
Details of the totally transparent hanging element with glossy white lacquered back panel.
Détails du volume suspendu complètement transparent avec la partie postérieure laquée blanc brillant.



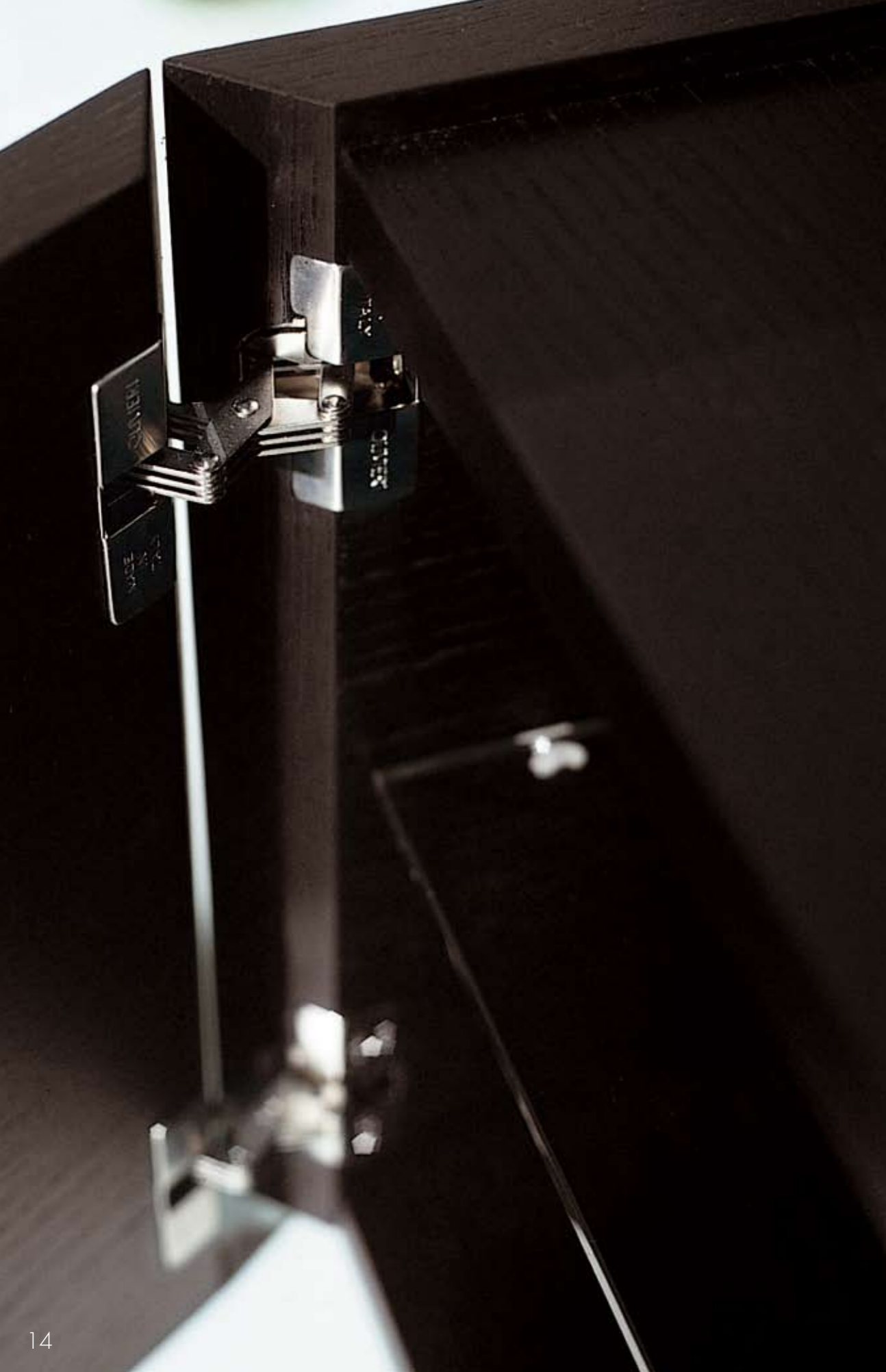

Ferramenta di qualità e lavorazione di pregio sono alcune delle caratteristiche dei mobili Olivieri, testimoniate in queste immagini dalle antine e dai fianchi con taglio a 45° del contenitore in rovere tinto wengé.
High quality hardware and precious manufacturing progress are some of the features of Olivieri furniture, shown on these pages from the doors and the side with 45° conjunction points of the veneered oak painted wengé container.
Ferrure et technique de travail de qualité sont les caractéristiques fondamentales des meubles de Olivieri, témoignées dans ces images par les portes et les côtés avec coupe à 45° du cube de rangement en chêne teint wengé.



17



I dettagli mostrano qualità estetiche e valori di accurata lavorazione. Sulla pedana in rovere grigio il contenitore a cassetti in appoggio laccato rosso scarlatto lucido. Il frontalino del cassetto evidenzia il taglio a 45° e la maniglia incassata sul top. The details show aesthetic qualities and particular manufacturing values. The "rosso scarlatto" glossy lacquered chest of drawers on the grey oak bench. The front side of the drawers shows the 45° cut and the top integrated handle. Les détails montrent les qualités esthétiques et des matériels. Sur l'estrade en chêne gris le cube de rangement avec tiroirs en appui laqué rouge écarlate brillant. La partie frontale du miroir met en évidence le coupe à 45° et la poignée encastrée sur le top.

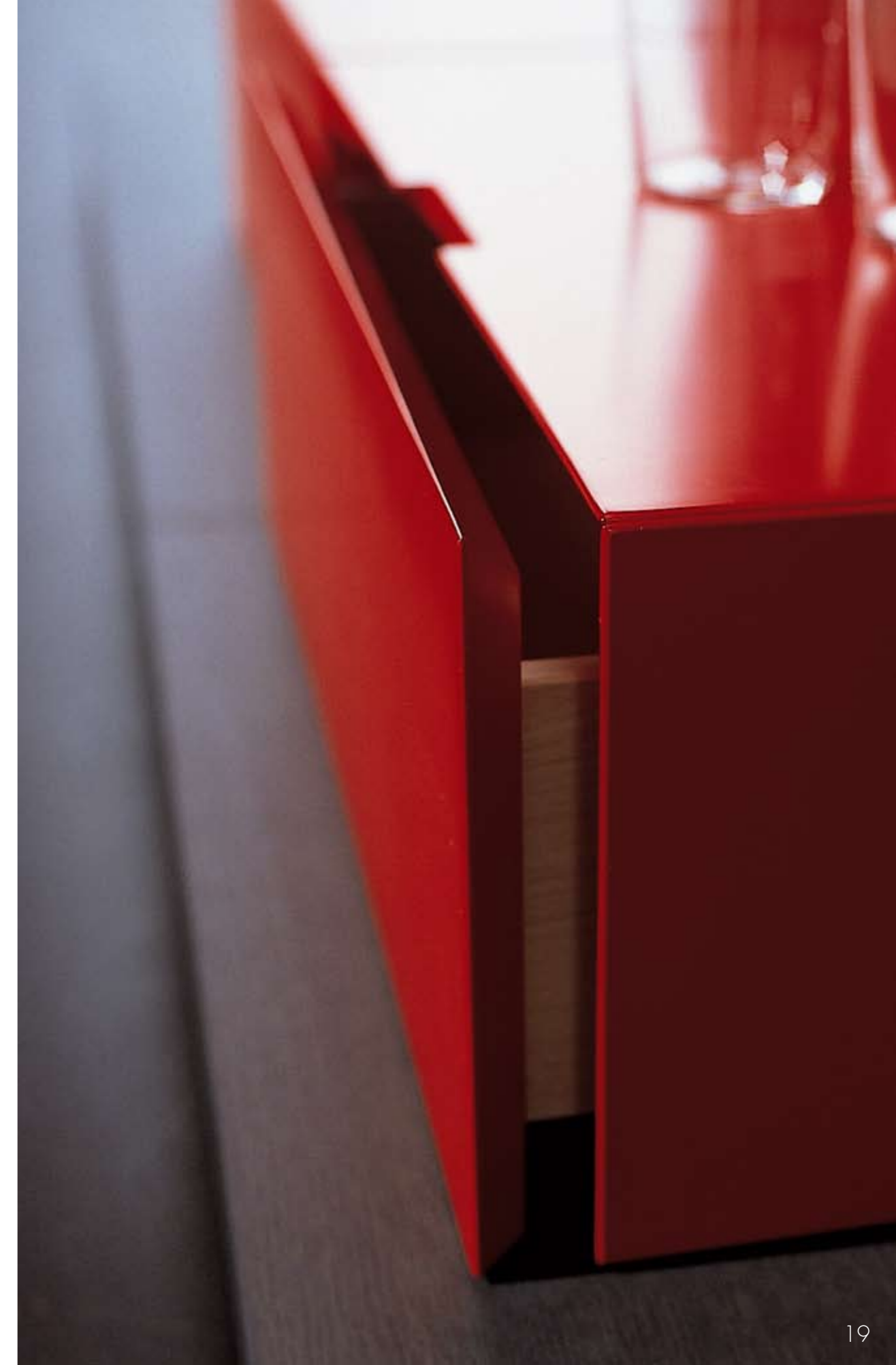



21

La mensola in metallo ha il supporto laccato opaco lucido oppure in essenza. La madia pensile in essenza ha sempre un'anta ribalta e un ampio cassetto.
The back panel of the metal shelf can be lacquered with mat or glossy colours or it can be in veneered wood. The wooden hanging breadbin is equipped with a flap door and a wide drawer.
L'étagère en métal a le support qui peut être laqué brillant ou opaque ou il peut être en bois. La huche murale en bois a toujours une porte à abattant et un grand tiroir.

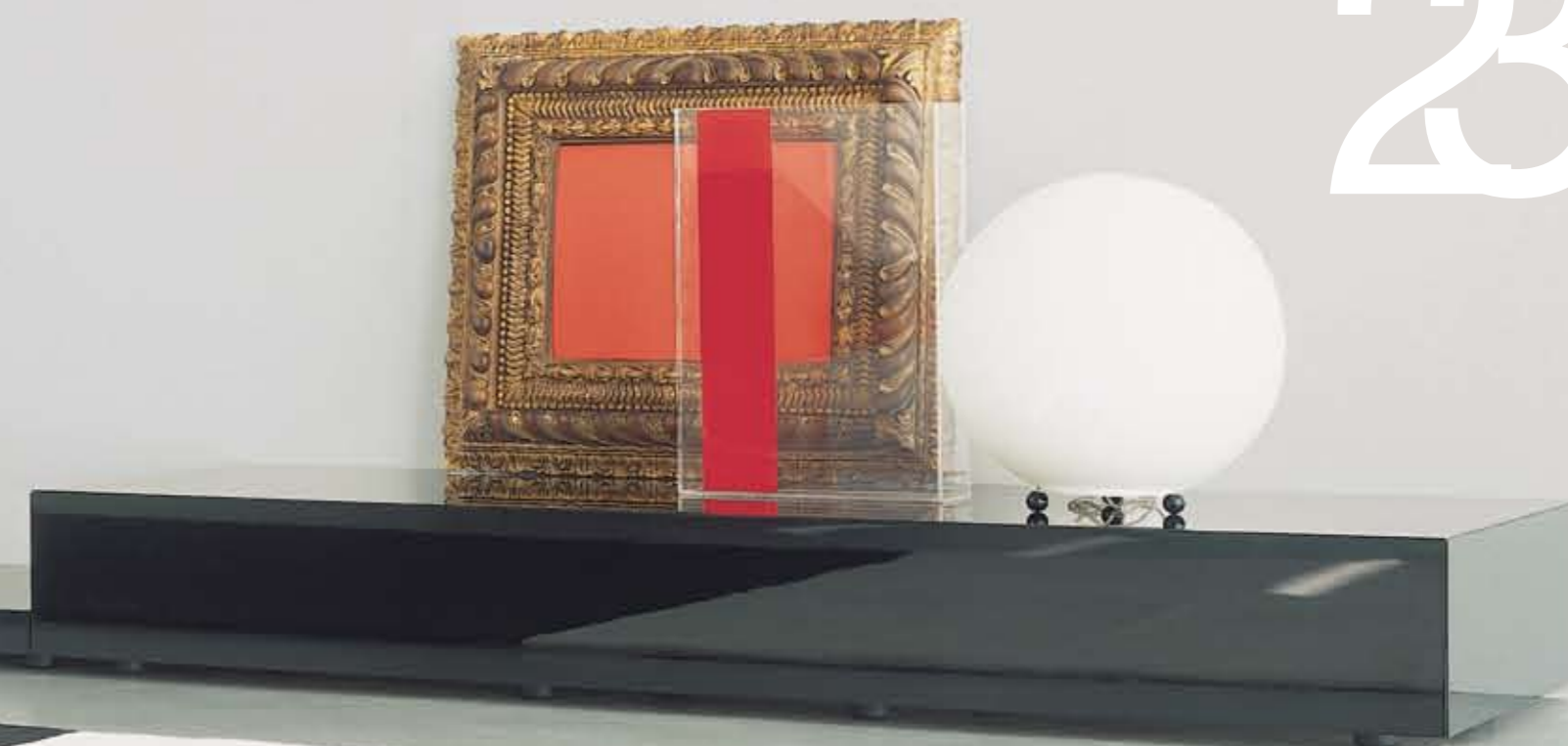

23



Credenza CUBE a tre ante in laccato lucido da cm.180 disponibile anche a due ante da 120 cm. All'interno un ripiano vetro.
Three doors glossy lacquered CUBE cupboard 180 cm., two doors version 120 cm. also available. The cupboard is equipped with an internal glass shelf.
Buffet CUBE à trois portes laquée brillant, longueur 180 cm., disponible aussi dans la version à deux portes, longueur 120 cm.
A l'intérieur étagère en verre

E
B
D
C



Ancora dettagli di qualità : gli angoli tagliati a 45° delle ante e del top consentono un'essenziale e rigoroso incrocio di linee che risulta evidente sulle estremità della base laccata.
Other quality details: 45° cut corners on doors and top allow a straight and essential lines crossing, more clear on the lacquered base sides.
Encore des détails de qualité: les angles coupés à 45° des portes et du top permettent un mariage essentiel et rigoureux des lignes qui apparaît évident sur les extrémités de la base laquée.

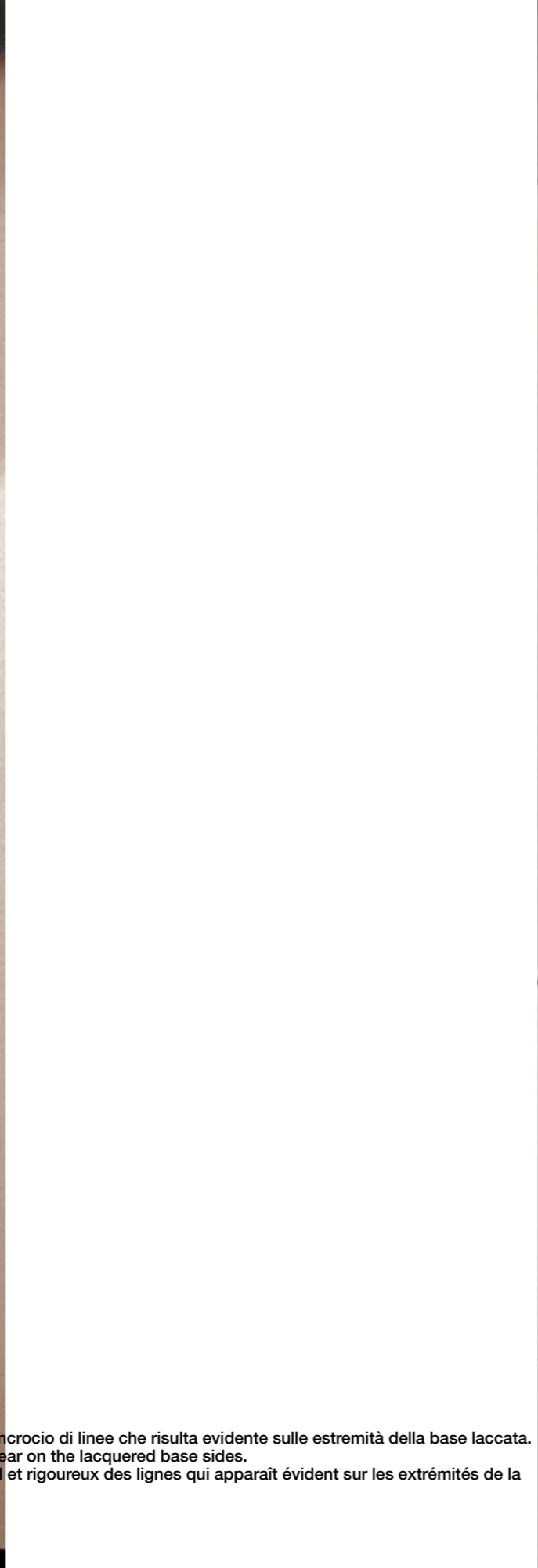

28



Composizione asimmetrica con credenza CUBE ad ante laccato lucido canapa. La pedana è in
vere tinto wengé e le mensole, nella stessa finitura, hanno luce incassata.
Asymmetric composition with cupboard CUBE whose doors are glossy "canapa" lacquered doors.
bench with oak painted wengé finishing and same finishing shelves with integrated light system.
Composition asymétrique avec crédence CUBE aux portes en laqué brillant couleur chanvre.
base est en chêne teint wengé et les étagères, avec la même finition, sont dotées d'une
mière encastrée.

30



Elegante composizione pranzo con doppia credenza pensile e tavolo AMBROGIO.
Mensoloni in essenza di grosso spessore. Sedia in cuoio JOLLY color naturale.
Smart dinner composition with double hanging CREDENZA CUBE and table AMBROGIO.
Thick wooden big shelves. CUOIO leather JOLLY chair in natural colour.
Elégante composition déjeuner avec double crédence murale et table AMBROGIO. Les
étagères en bois ont une épaisseur considérable. Chaise en cuir JOLLY en couleur naturelle.

Particolare del vetro laccato usato come top della credenza pensile in wengé.
Detail of the lacquered glass used as top cover for the hanging cupboard in veneered oak painted wengé.
Détail du verre lacqué utilisé comme top de la crédence murale en chêne teinté wengé.



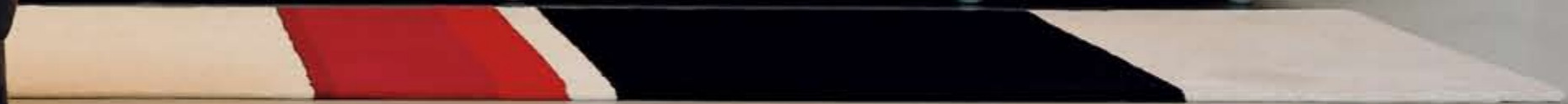

36





3

3



TECNICAL DATA

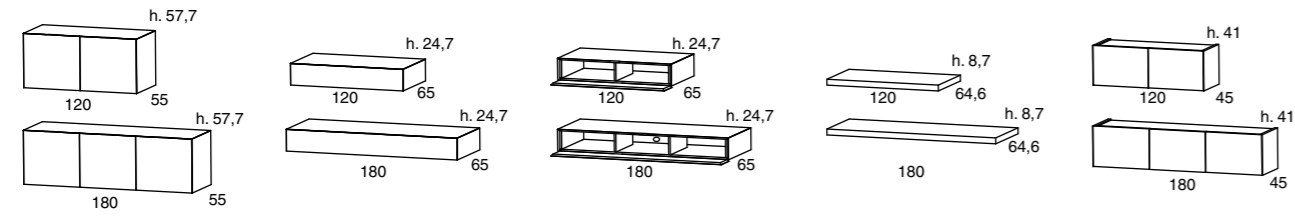

CREDENZA CUBE
 PANCA
 PANCA CON FLAP
 PORTA DECODER
 PEDANA
 CREDENZA PENSILE

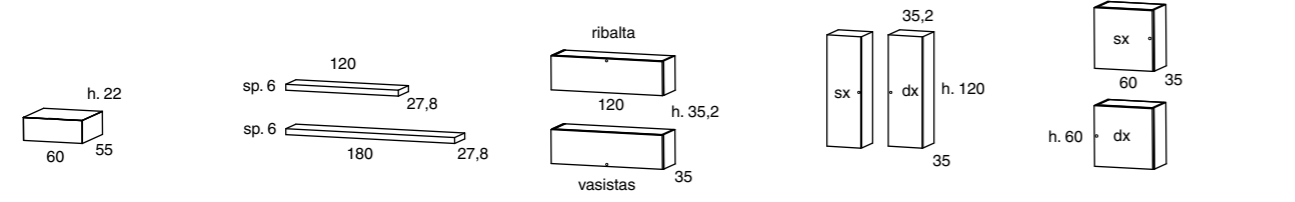

CASSETTO
 D'ARROGGIO
 MENSOLONI
 PENSILI RIBALTA
 E VASISTAS
 PENSILE VERTICALE
 PENSILE 60X60
 BATTENTE

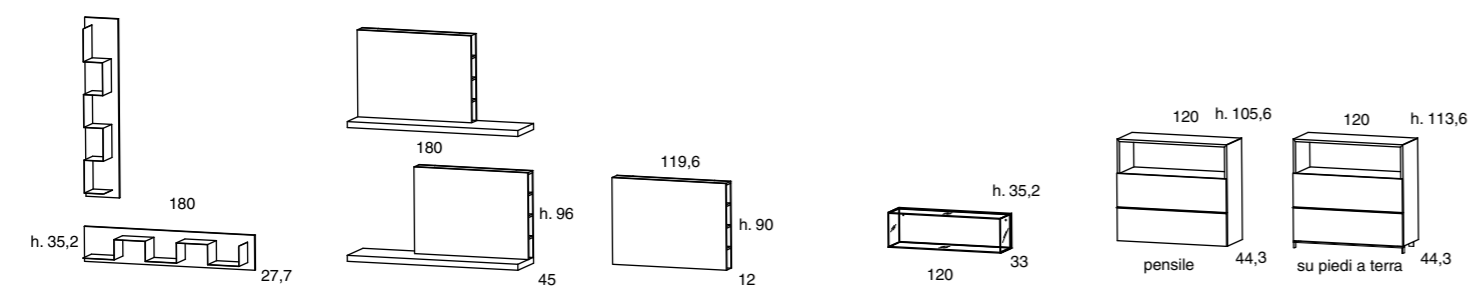

MENSOLA METALLO
 MENSOLONE CON
 PANNELLO ATTREZZATO
 PER TV AL PLASMA
 PANNELLO ATTREZZATO
 PER TV AL PLASMA
 PENSILE VETRO
 MADIA